

# JP and JP Booster

Installation and operating instructions



## Original installation and operating instructions

## Table of contents

<b>1. General information</b>	<b>5</b>
1.1 Target group	5
1.2 Hazard statements	5
1.3 Notes	5
<b>2. Receiving the product</b>	<b>5</b>
2.1 Inspecting the product	5
2.2 Scope of delivery, JP	5
2.3 Scope of delivery, JP Booster	6
<b>3. Installing the product</b>	<b>6</b>
3.1 Location	6
3.2 Mechanical installation	6
3.3 Electrical connection	8
<b>4. Startup of the product</b>	<b>10</b>
4.1 Priming the product	11
4.2 Starting up the product	11
<b>5. Product introduction</b>	<b>11</b>
5.1 Product overview, JP	12
5.2 Product overview, JP Booster	12
5.3 Intended use	12
5.4 Pumped liquids	12
5.5 Identification	13
<b>6. Service</b>	<b>13</b>
6.1 Maintenance	13
6.2 Maintaining the pressure tank	13
6.3 Service kits	13
<b>7. Taking the product out of operation</b>	<b>14</b>
7.1 Draining JP and JP PT-V	14
7.2 Draining JP PT-H	14
7.3 Storage of the product	14
7.4 Frost protection	14
<b>8. Fault finding the product</b>	<b>14</b>
8.1 The pump does not start	15
8.2 The pump stops unexpectedly during operation and starts again after a while	15
8.3 The pump runs, but does not deliver the expected amount of water	15
8.4 Fault finding boosters with a pressure manager	15
8.5 Fault finding boosters with a pressure tank	16
<b>9. Technical data</b>	<b>17</b>
9.1 Operating conditions	17
9.2 Head and flow rate	17
9.3 Inlet pressure	17
9.4 Miscellaneous data	17
<b>10. Disposing of the product</b>	<b>17</b>

## 1. General information

This appliance can be used by children aged from 8 years and above and persons with reduced physical, sensory or mental capabilities or lack of experience and knowledge if they have been given supervision or instruction concerning use of the appliance in a safe way and understand the hazards involved.

Children shall not play with the appliance. Cleaning and user maintenance shall not be made by children without supervision.



Read this document before you install the product. Installation and operation must comply with local regulations and accepted codes of good practice.

## 1.1 Target group

These installation and operating instructions are intended for professional as well as non-professional users.

## 1.2 Hazard statements

The symbols and hazard statements below may appear in Grundfos installation and operating instructions, safety instructions and service instructions.

**DANGER**

Indicates a hazardous situation which, if not avoided, will result in death or serious personal injury.

**WARNING**

Indicates a hazardous situation which, if not avoided, could result in death or serious personal injury.

**CAUTION**

Indicates a hazardous situation which, if not avoided, could result in minor or moderate personal injury.

The hazard statements are structured in the following way:

**SIGNAL WORD****Description of the hazard**

Consequence of ignoring the warning

- Action to avoid the hazard.

## 1.3 Notes

The symbols and notes below may appear in Grundfos installation and operating instructions, safety instructions and service instructions.



Observe these instructions for explosion-proof products.



A blue or grey circle with a white graphical symbol indicates that an action must be taken.



A red or grey circle with a diagonal bar, possibly with a black graphical symbol, indicates that an action must not be taken or must be stopped.



If these instructions are not observed, it may result in malfunction or damage to the equipment.



Tips and advice that make the work easier.

## 2. Receiving the product

## 2.1 Inspecting the product

On receipt of the product, do the following:

- Check that the product is as ordered.  
If the product is not as ordered, contact the supplier.
- Make sure that the supply voltage and frequency correspond to the values stated on the product nameplate.

## Related information

[5.5.1 Nameplate example for JP and JP Booster](#)

## 2.2 Scope of delivery, JP

The box contains the following items:

- 1 Grundfos JP pump
- 1 lifting-handle kit
- 1 quick guide
- 1 safety instructions booklet.

## 2.3 Scope of delivery, JP Booster

The box contains the following items:

- 1 Grundfos JP Booster
- 1 quick guide
- 1 safety instructions booklet.

## 3. Installing the product

### 3.1 Location

The product can be installed both indoors and outdoors. Use a suitable cover to protect the product from direct sunlight, rain or snow.

Please observe the following:

- Install the product in a well-ventilated location to ensure cooling of its components.
- Install the product to enable easy inspection, maintenance and service.
- We recommend that you place the product as close to the liquid to be pumped as possible.
- We recommend that you install the product near a drain or in a drip tray connected to a drain in order to lead away possible condensation from cold surfaces.

### Related information

#### 3.1.2 Ambient temperature during operation

#### 3.1.1 Installation of the product in a frosty environment

Protect the product from freezing if it is to be installed outdoors where frost may occur.

#### 3.1.2 Ambient temperature during operation

The ambient temperature must not exceed 55 °C.

### Ambient temperature

Up to 40 °C	The pump can run continuous operation.
40 to 55 °C	The overheating protection ensures that the pump runs intermittent operation when the air temperature is too high to cool the motor efficiently. Example of intermittent cycle: the pump runs for 20 minutes and stops for 40 minutes before it starts again. See the table below.

### Intermittent operation (S3 mode)

40-55 °C	50 Hz	60 Hz
JP 3-42	ON: 20 min OFF: 40 min	ON: 20 min OFF: 40 min
JP 4-47	ON: 15 min OFF: 45 min	ON: 10 min OFF: 50 min
JP 4-54	ON: 20 min OFF: 40 min	ON: 20 min OFF: 40 min
JP 5-48	ON: 20 min OFF: 40 min	ON: 30 min OFF: 30 min

### Related information

#### 3.1 Location

#### 3.1.3 Minimum space

Ensure sufficient space for service and maintenance and for motor cooling.

- We recommend a clearance of 0.5 m on three sides of the product.
- The motor is fan cooled, so do not block the fan cover.
- If you install the product with one side against a wall, make sure that the nameplate is visible.

## 3.2 Mechanical installation

- WARNING**  
**Electric shock**  
Death or serious personal injury
- Switch off the power supply before you start any work on the product. Make sure that the power supply cannot be switched on accidentally.

- CAUTION**  
**Crushing of feet**  
Minor or moderate personal injury
- Wear safety shoes when handling the product.

- CAUTION**  
**Impurities in the water**  
Minor or moderate personal injury
- Before the pump is used for supplying drinking water, flush the pump thoroughly with clean water.

### 3.2.1 Mounting the product

- Place the product in a horizontal position with a maximum inclination angle of  $\pm 5^\circ$ . The base plate must be facing downwards.
- Fasten the product to a solid horizontal foundation by means of screws through the holes in the base plate.

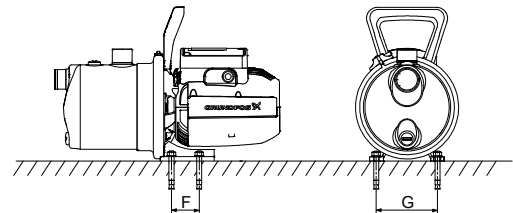

Fig. Foundation of a JP pump

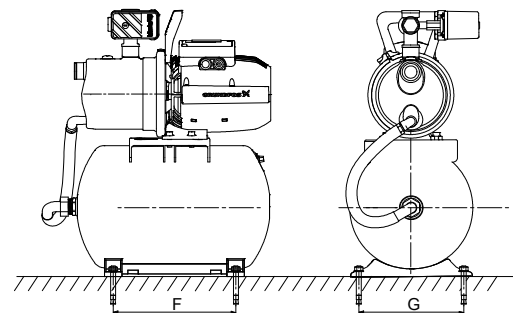
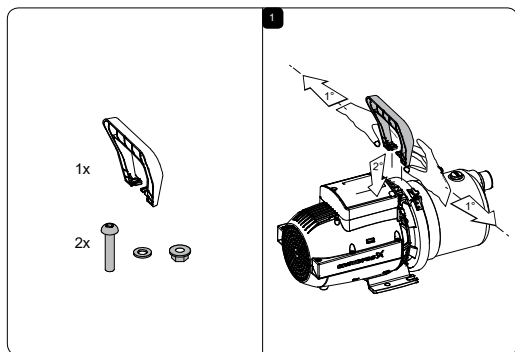

Fig. Foundation of JP PT-H Booster

	JP pump [mm]	JP PT-H Booster [mm]
F	47	265
G	110	230

### 3.2.2 Attaching the lifting handle

The handle is supplied with the JP pump. It is optional to attach the handle on the pump, for example on permanently installed pumps.



TM072418

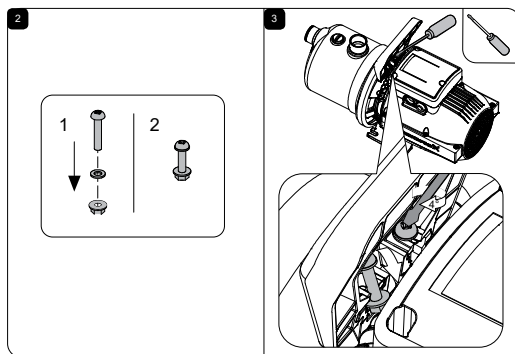

TM072419

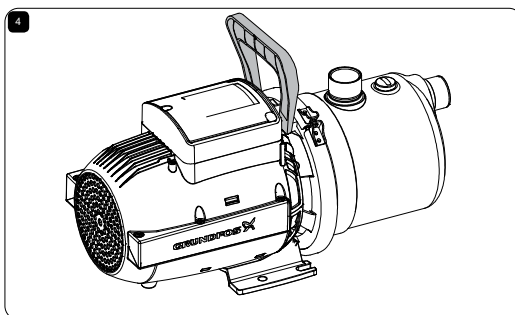

TM072480

Fig. How to attach the lifting handle on the pump

### 3.2.3 Connecting the pipe system

! Install the product so that it is not stressed by the pipe system.

Pipe dimensions:

- ! The diameter of the inlet pipe must be larger than 1", if the inlet pipe is longer than 10 m, or if the suction lift exceeds 4 m.
- If a hose is used as inlet pipe, it must be non-collapsible.

💡 We recommend that you install isolating valves on both the inlet and outlet side of the pump.

1. Seal the pipe fittings with thread sealing tape or similar.
2. Connect pipes to the inlet and outlet port on the pump. Do not let the pump support the pipes.  
Use a pipe wrench or similar tool.
3. Fit a foot valve to the inlet pipe if the pump is installed above the liquid level, for example if you pump from a well, tank or reservoir. We recommend a foot valve with strainer.
4. We recommend that you install a filter on the inlet side to protect the pump from sand, gravel or other debris if the pump is to be used for pumping rainwater or well water.
5. Make sure that the inlet pipe has a gradual upward slope of 5° towards the pump to avoid air pockets, especially under suction-lift conditions.

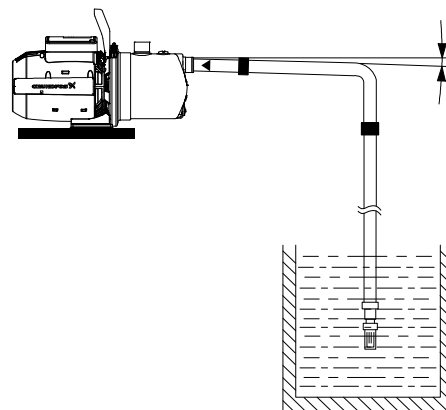

TM064532

Fig. Inlet pipe with gradual upward slope towards the pump

#### 3.2.3.1 Maximum system pressure

! Make sure that the system in which the pump is installed is designed for the maximum pump pressure.

The maximum inlet pressure depends on the head at the actual duty point. The sum of the inlet pressure and the head must not exceed the maximum system pressure.

We recommend that you install a pressure-relief valve to protect the pump so that the outlet pressure does not exceed the maximum system pressure.

#### 3.2.3.2 Inlet and outlet pipes

Please follow these general precautions when connecting the inlet and outlet pipes.

! Do not let the pump support the pipes. Use pipe hangers or other supports at proper intervals to provide pipe support near the pump.

! The internal diameter of the pipes must never be smaller than the diameter of the pump ports.

- Install the pipes so that air pockets are avoided, especially on the inlet side of the pump.
- Use eccentric reducers with the tapered side down.
- Make sure the pipes are as straight as possible to avoid unnecessary bends and fittings. We recommend long-radius 90° pipe bends to decrease friction loss.
- Run the inlet pipe as direct as possible and, ideally, make sure the length is at least ten times the pipe diameter.
- If possible, run a horizontal inlet line. We recommend a gradual upward slope to pumps operating in suction-lift conditions, and a gradual downward slope to pumps operating in positive inlet-pressure conditions.

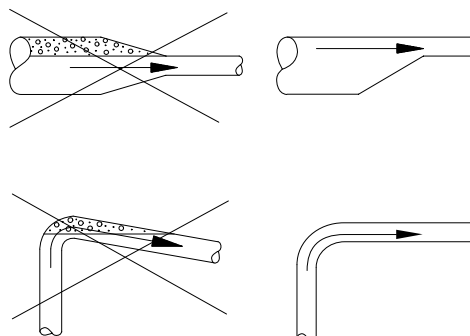

TM040338

Fig. Recommended pipe installation to avoid friction and air pockets

- A short pipe must be the same diameter as the inlet port or larger.
- A long pipe must be one or two sizes larger than the inlet port, depending on the length.

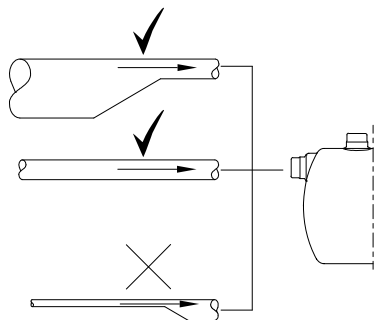

**Fig.** Correct pipe sizing for connection to the pump inlet or outlet

TM058227

### 3.2.4 Installation examples

We recommend that you follow the installation examples. Valves are not supplied with the pump.

#### 3.2.4.1 Suction from a tank

This installation example shows JP PM, but it applies to all variants of the JP range.

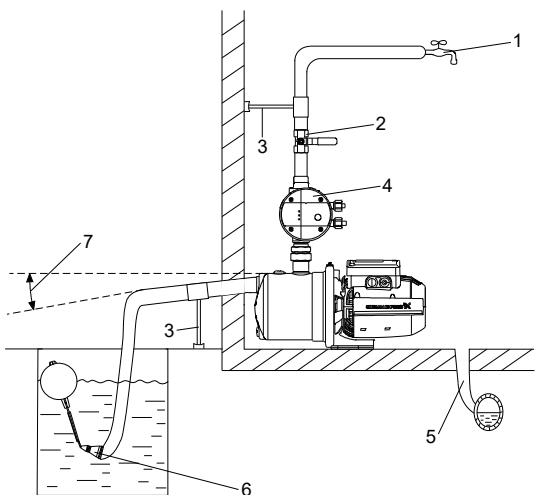

TM072435

Pos.	Description
1	Highest tapping point.
2	Isolating valve.
3	Pipe support.
4	Pressure manager.
5	Drain to sewer.
6	Strainer. A foot valve is optional. We recommend using a foot valve together with JP PM.
7	5 ° angle.

#### 3.2.4.2 Suction from a well

This installation example shows the JP PM, but it applies to all variants of the JP range.

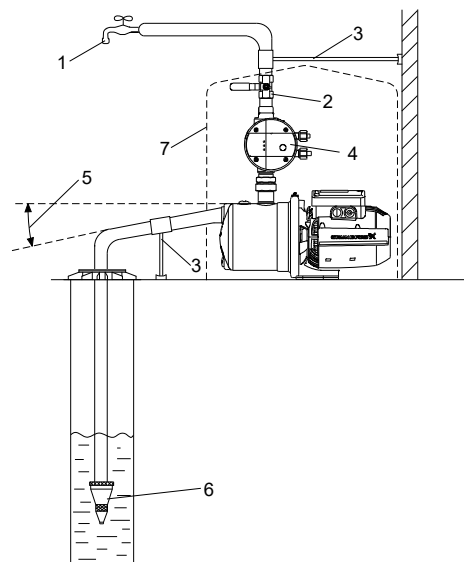

TM072434

Pos.	Description
1	Highest tapping point.
2	Isolating valve.
3	Pipe support.
4	Pressure manager.
5	5 ° angle.
6	Foot valve with strainer. The foot valve is optional. We recommend using a foot valve together with JP PM.
7	Pump cover.

### 3.3 Electrical connection

#### WARNING

##### Electric shock

Death or serious personal injury

- Switch off the power supply before you start any work on the product. Make sure that the power supply cannot be switched on accidentally.



#### WARNING

##### Electric shock

Death or serious personal injury

- The product is supplied with a grounding conductor and grounding-type attachment plug. To reduce the risk of electric shock, be certain that the product is connected only to a properly grounded, grounding-type receptacle (protective earth).



#### WARNING

##### Electric shock

Death or serious personal injury

- If national legislation requires a residual-current device (RCD) or equivalent in the electrical installation, this must be type A or better.



#### WARNING

##### Electric shock

Death or serious personal injury

- If the product is used for cleaning or maintenance of swimming pools, garden ponds or similar places, make sure that the product is supplied through a residual-current device (RCD) with a rated residual operating current not exceeding 30 mA.



All electrical connections must be carried out by qualified persons in accordance with local regulations.

- ! Make sure that the electrical installation supports the rated current [A] of the product. See the product's nameplate.

### 3.3.1 Connecting products with a plug

**WARNING**  
**Electric shock**

Death or serious personal injury



- Make sure that the power-supply plug delivered with the product is in compliance with local regulations.
- The plug must have the same protective earth (PE) connection system as the power outlet. If not, use a suitable adapter if allowed by local regulations.

- ! Do not turn on the power supply until the pump has been filled with liquid.

1. Switch off the power supply to the power socket.
2. Connect the plug to the power socket.

### 3.3.2 Connecting products without a plug

**WARNING**  
**Electric shock**

Death or serious personal injury



- Power supply cables without a plug must be connected to a supply disconnecting device incorporated in the fixed wiring according to the local wiring rules.

- ! Do not turn on the power supply until the pump has been filled with liquid.

If the product is delivered with a cable but without a plug, connect the cable to the external main switch or attach a plug.

#### Connecting the cable to an external main switch

1. Strip the cable.
2. Thread each individual wire to the correct terminal in the external main switch.

#### Wiring a plug

1. Strip the cable.
2. Loosen the two screws holding the cable clamp and pull the cable through.
3. Thread each individual wire to the correct terminal.
4. Tighten the terminal screws and the cable clamp screw. Make sure not to overtighten the cable clamp screw.

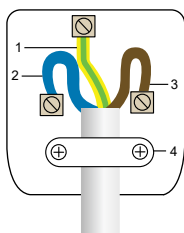

TM072505

Fig. Example, plug wiring

Pos.	Description
1	E: Earth, yellow and green wire
2	N: Neutral, blue wire
3	L: Live, brown wire
4	Cable clamp

#### Related information

[3.3.3 Connecting products without a cable](#)

### 3.3.3 Connecting products without a cable

**WARNING**  
**Electric shock**

Death or serious personal injury



- Power supply cables without a plug must be connected to a supply disconnecting device incorporated in the fixed wiring according to the local wiring rules.



- ! Do not turn on the power supply until the pump has been filled with liquid.

If the product is delivered without a cable, please connect the pump to the power supply using one of the following cable types:

Pump model	Recommended cable type
JP 3-42 and JP 4-47	H05 RN-F
JP 4-54 and JP 5-48	H07 RN-F

Do as follows to connect the cable to the pump:

1. Remove the top cover on the motor by loosening the screws.
2. Locate the power-supply terminal and cable clamp inside the terminal box.
3. Loosen the cable clamp.
4. Pull one end of the cable through the cable gland located on the side of the terminal box.

5. Strip the cable conductors and add cable shoes.

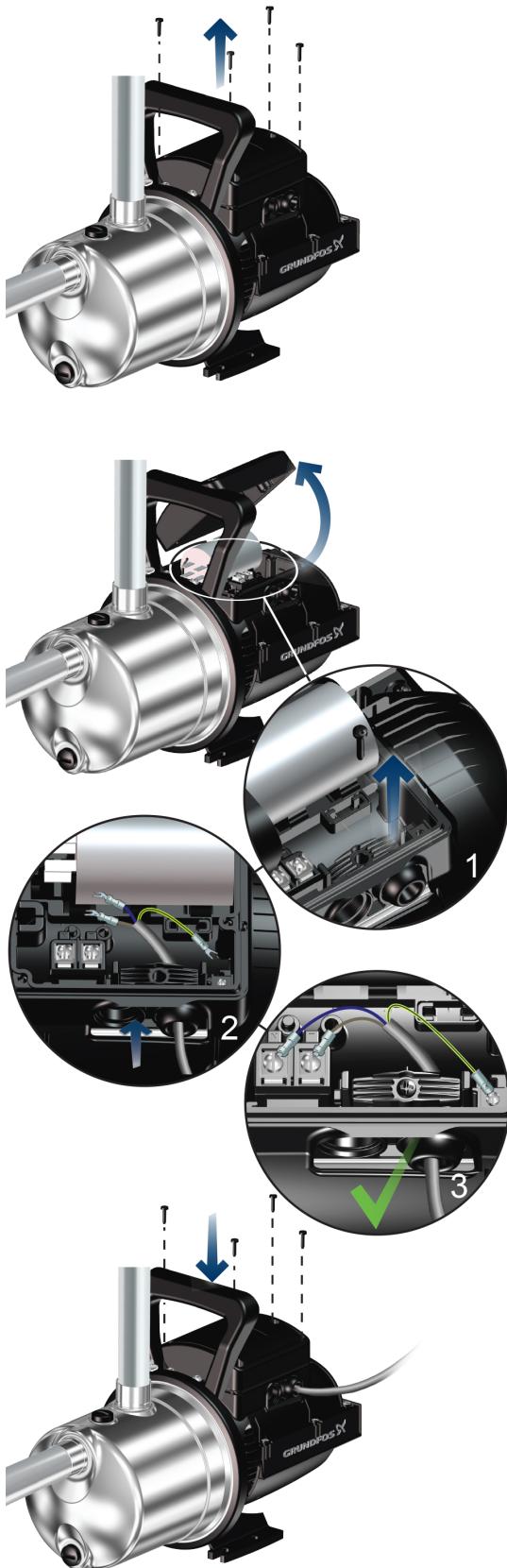

6. Connect the cable conductors to the power-supply terminal. See wiring diagram.
7. Tighten the terminal screws and the cable clamp screw. Make sure not to overtighten the cable clamp screw.
8. Refit the top cover and tighten the screws.
9. Strip the other end of the cable and connect it to a plug or an external main switch.

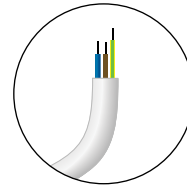

#### Related information

[3.3.2 Connecting products without a plug](#)

[3.3.4 Wiring diagram](#)

#### 3.3.4 Wiring diagram

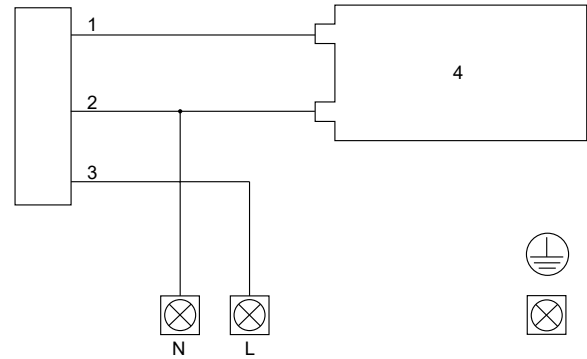

Pos.	Description
1	Red
2	Blue
3	Black
4	Capacitor

#### Related information

[3.3.3 Connecting products without a cable](#)

#### 3.3.5 Motor protection

The pump incorporates current- and temperature-dependent motor protection. If the pump is running without water, is blocked or otherwise overloaded, the built-in thermal switch will cut out. When the motor has cooled sufficiently, it will restart automatically. No external motor protection is required.

#### 4. Startup of the product

##### WARNING

##### Electric shock



Death or serious personal injury

- Do not use the product for cleaning and other maintenance of swimming pools or similar places if there are people in the water.

##### CAUTION

##### Hot surface



Minor or moderate personal injury

- Use protective gloves if the liquid or ambient temperature is higher than 40 °C.

##### CAUTION

##### Hot surface



Minor or moderate personal injury

- Do not run the pump continuously with a closed inlet or outlet valve.

##### CAUTION

##### Hot or cold liquid



Minor or moderate personal injury

- Make sure that escaping hot or cold liquid does not cause injury to persons or damage to the equipment.

TM072423

TM072433

TM072335

- ! Do not turn on the power supply until the pump has been filled with liquid.
- ! The number of starts and stops must not exceed 20 times per hour.
- ! The pump must not run without delivering water for more than 5 minutes.
- ! Only use the product for the intended use and for the pumped liquids stated in these installation and operating instructions.

## Related information

[5.3 Intended use](#)

[5.4 Pumped liquids](#)

## 4.1 Priming the product

- ! Always tighten the priming plug by hand.

1. Unscrew the priming plug.
2. Fill the pump with water.
3. Refit the priming plug and tighten by hand.

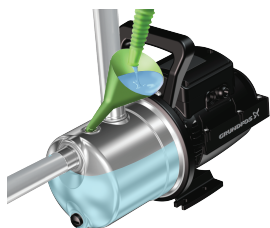
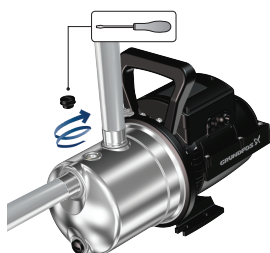

## 4.2 Starting up the product

After installing the product, do the following:

1. Open all isolating valves. Make sure that the water supply is sufficient on the inlet side of the pump.
2. Turn on the power supply to the pump, and the pump will start. If there is a suction lift, it can take up to five minutes before the pump delivers water. This period depends on the length and diameter of the inlet pipe.
3. Open the tapping point that is highest or furthest away from the pump to let out air trapped in the system.

4. When water flows through the tapping point, close it.
5. Startup is completed, and the pump is ready for operation.

### 4.2.1 Startup of JP PM

For JP pumps with pressure manager, please see the PM 1/PM 2 quick guide for instructions on how to start up the product.



<http://net.grundfos.com/qr/i/98388184>

- ! If a pressure is not built up in the system within five minutes after startup, the dry-running protection will be activated and the pump will be stopped. Check the priming conditions of the pump before attempting to restart it.

### 4.2.2 Shaft seal run-in

The shaft seal faces are lubricated by the pumped liquid. A slight leakage from the shaft seal of up to 10 ml per day or 8 to 10 drops per hour may occur. Under normal conditions, the leaking liquid will evaporate. As a result, no leakage will be detected.

When the pump is started for the first time, or when the shaft seal has been replaced, a certain run-in period is required before the leakage is reduced to an acceptable level. The time required for this depends on the operating conditions, that is, every time the operating conditions change, a new run-in period will be started. Leaking liquid will drain through the drain holes in the motor flange. Install the product in such a way that leakage cannot cause undesirable collateral damage.

## 5. Product introduction

Grundfos jet pumps and boosters are designed for domestic use and ensure a constant supply of clean water to households and gardens as well as light commercial applications.

### JP

JP is a self-priming, single-stage centrifugal jet pump. The jet pump has excellent suction capacity and is designed for long and trouble-free operation. The built-in ejector with guide vanes ensures optimum self-priming properties. JP is small and compact, and the lifting handle makes JP handy and easy to carry. The pump housing is made of stainless steel.

### JP Boosters

JP Boosters are compact systems for pressure boosting with pressure control. The pressure control gives more comfort to the user, as it allows the pump to start and stop automatically according to demand.

JP Boosters are available in the following variants:

- JP PM: a jet pump with a pressure manager (Grundfos PM 1)
- JP PT-V: a jet pump with a vertical pressure tank and a pressure switch
- JP PT-H: a jet pump with a horizontal pressure tank and a pressure switch.

### AISI 316 variant

A special variant of the JP pump is available with components made with a higher stainless-steel grade. This pump is especially suitable for pool-cleaning applications.

TMD72401

QR98604589



5.1 Product overview, JP

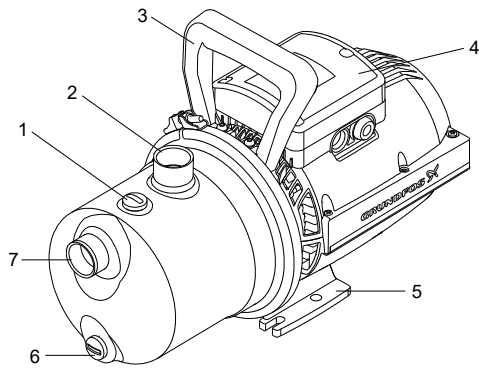

TM072509

Pos.	Description
1	Priming plug
2	G1 outlet connection
3	Lifting handle
4	Terminal box and cable connection
5	Base plate
6	Drain plug
7	G1 inlet connection

5.2 Product overview, JP Booster

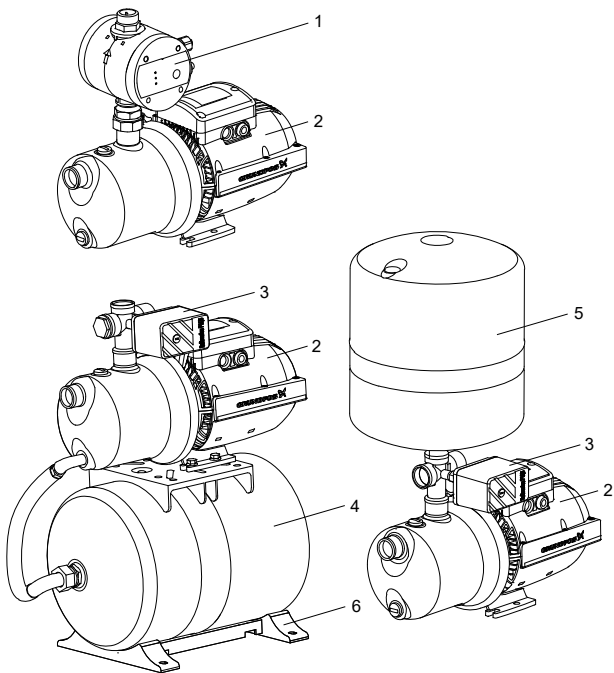

TM072656

Fig. JP PM (top), JP PT-H (left), JP PT-V (right)

Pos.	Description
1	Pressure Manager
2	JP pump
3	Pressure switch
4	Pressure tank, horizontal
5	Pressure tank, vertical
6	Base plate

5.3 Intended use

**!** Only use the product according to the specifications stated in these installation and operating instructions.

The product is suitable for pressure boosting of clean water in domestic water-supply systems.

Related information

- 4. Startup of the product
- 5.4 Pumped liquids

5.3.1 Intended use of the AISI 316 variant

**WARNING**  
**Electric shock**  
 Death or serious personal injury  
 - Do not use the product for cleaning and other maintenance of swimming pools or similar places if there are people in the water.

**CAUTION**  
**Impurities in the water**  
 Minor or moderate personal injury  
 - Do not use the product for drinking water.

The AISI 316 variant of the JP pump is especially suitable for pool-cleaning applications.

5.4 Pumped liquids

**WARNING**  
**Flammable material**  
 Death or serious personal injury  
 - Do not use the product for flammable liquids such as diesel oil, petrol or similar liquids. The product must only be used for water.

**WARNING**  
**Toxic material**  
 Death or serious personal injury  
 - Do not use the product for toxic liquids. The product must only be used for water.

**WARNING**  
**Corrosive substance**  
 Death or serious personal injury  
 - Do not use the product for aggressive liquids. The product must only be used for water.

**!** If the water contains sand, gravel or other debris, there is a risk of pump blockage and pump damage. Install a filter on the inlet side or apply a floating strainer to protect the pump.

The product is suitable for pumping clean, thin, non-aggressive, non-toxic and non-explosive liquids without solid particles or fibres. Examples of liquids:

- potable water
- rainwater.

Related information

- 4. Startup of the product
- 5.3 Intended use

## 5.5 Identification

### 5.5.1 Nameplate example for JP and JP Booster

Pos.	Description
1	Type
2	Min. flow rate and max. flow rate
3	Min. head and Max. head
4	Max. pressure
5	Supply voltage and Frequency
6	Full-load current
7	Approvals
8	Power consumption
9	Rated power
10	Country of origin
11	Capacitor data
12	Speed of rotation
13	Serial number
14	Insulation class
15	Enclosure class
16	Factory and production code, year and week
17	Product number
18	Max. ambient temperature
19	Max. liquid temperature

Pos.	Description
1	Type
2	Min. flow rate and max. flow rate
3	Min. head and Max. head
4	Max. pressure
5	Supply voltage and Frequency
6	Full-load current
7	Approvals
8	Power consumption
9	Rated power
10	Country of origin
11	Capacitor data
12	Speed of rotation
13	Serial number
14	Insulation class
15	Enclosure class
16	Factory and production code, year and week
17	Product number
18	Max. ambient temperature
19	Max. liquid temperature

### Related information

#### 2.1 Inspecting the product

### 5.5.2 Type key, JP pump and booster

Example:

JP . 3- . 42 . PT- . V . 1x230 V . 50 Hz . 2m . SCHUKO . HU

	Description
JP	Jet Pump
3-	Max. flow rate [m³/h]
42	Max. head [m]
PT-	Booster type, if applicable: <ul style="list-style-type: none"> <li>PT: Pressure Tank</li> <li>PM: Pressure Manager</li> <li>PS: Pressure Switch</li> </ul>
V	Tank type, if applicable: <ul style="list-style-type: none"> <li>V: Vertical</li> <li>H: Horizontal</li> </ul>
1x230 V	Voltage [V]

	Description
50 Hz	Frequency [Hz]
2m	Cable length [m]
SCHUKO	Plug type
HU	Country of origin

## 6. Service

### WARNING

#### Electric shock



Death or serious personal injury

- Switch off the power supply before you start any work on the product. Make sure that the power supply cannot be switched on accidentally.

### WARNING

#### Chemical hazard



Death or serious personal injury

- Make sure that the product has only been used for water. If the product has been used for pumping aggressive liquids, flush the system with clean water before you start work on the product.

### WARNING

#### Pressurised system



Death or serious personal injury

- Before dismantling the pump, drain the system or close the isolating valves on both sides of the pump. Slowly loosen the drain plug and unpressurise the system.

### CAUTION

#### Impurities in the water



Minor or moderate personal injury

- Before the pump is used for supplying drinking water, flush the pump thoroughly with clean water.



Only qualified persons are allowed to service the pump.

### 6.1 Maintenance

The product is maintenance-free during normal operation. For cleaning, use a dry and dust-free cloth.

### 6.2 Maintaining the pressure tank

Check the precharge pressure annually.

The pressure tanks are supplied from factory with a precharge pressure. See tank nameplate.

Do not use a tank with signs of damage, such as dents, leakage or corrosion.

#### 6.2.1 Adjusting the precharge pressure

### CAUTION

#### Pressurised system



Minor or moderate personal injury

- Before starting work on the product, make sure there is no system pressure on the tank.
- Disconnect pumps or switch off the power supply.

1. Make sure that there is no water pressure in the tank. Switch off the pump and open a tap, or close the isolating valves and drain the pump.
2. Use a suitable pressure gauge to check the precharge pressure.
3. Release or add compressed air to make the precharge pressure equal to the recommended precharge pressure.
4. If water escapes during the precharge-pressure check, the membrane is defective.

### 6.3 Service kits

For further information on service kits, see Grundfos Product Center at [www.product-selection.grundfos.com](http://www.product-selection.grundfos.com).

## 7. Taking the product out of operation

### WARNING Electric shock



Death or serious personal injury

- Switch off the power supply before you start any work on the product. Make sure that the power supply cannot be switched on accidentally.

If the product is taken out of operation for a period of time, for example during winter, it must be disconnected from the power supply and placed in a dry location. Do as follows:

1. Disconnect the product from the power supply.
2. Open a tap to release the pressure in the pipe system.
3. Close the isolating valves and/or drain the pipes.
4. Gradually loosen the drain plug to release the pressure in the product.
5. Drain the product.
6. Store the product according to the recommended storing conditions.

### Related information

[7.1 Draining JP and JP PT-V](#)

[7.2 Draining JP PT-H](#)

[7.3 Storage of the product](#)

### 7.1 Draining JP and JP PT-V

To drain the JP pump and JP Booster with a vertical pressure tank, do as follows:

1. Unscrew the drain plug using a screw driver.
2. Let the water flow out of the pump.
3. When the pump is empty, refit the plug by hand.



### Related information

[7. Taking the product out of operation](#)

### 7.2 Draining JP PT-H

To drain JP Booster with a horizontal pressure tank, do as follows:

1. Drain the pump by removing the drain plug.
2. Unscrew the hose on the tank.
3. Tilt the tank so that the water flows out.
4. When the tank is empty, refit the hose.

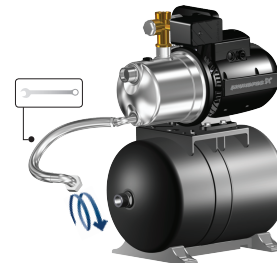
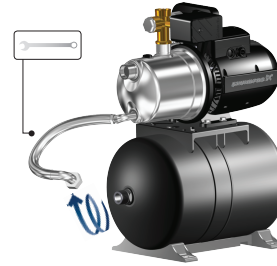

### Related information

[7. Taking the product out of operation](#)

### 7.3 Storage of the product

#### WARNING Electric shock



Death or serious personal injury

- Switch off the power supply before you start any work on the product. Make sure that the power supply cannot be switched on accidentally.

If the product is to be stored for a period of time, for example during winter, drain it by removing the drain plug and store the product indoors in a dry location.

During storage the temperature must be between -40 and +70 °C and have a maximum relative humidity of 98 % RH.

### Related information

[7. Taking the product out of operation](#)

### 7.4 Frost protection

If the product is not used during periods of frost, it must be drained to avoid damage.

## 8. Fault finding the product

#### WARNING Electric shock



Death or serious personal injury

- Switch off the power supply before you start any work on the product. Make sure that the power supply cannot be switched on accidentally.

**WARNING****Chemical hazard**

Death or serious personal injury

- Make sure that the product has only been used for water. If the product has been used for pumping aggressive liquids, flush the system with clean water before you start work on the product.

**WARNING****Pressurised system**

Death or serious personal injury

- Before dismantling the product, drain the system or close the isolating valves on both sides of the product. Slowly loosen the drain plug and unpressurise the system.

**8.1 The pump does not start**

- Cause** Supply failure.
- Remedy** Cut in the circuit breaker or replace the fuses. If the new fuses also blow, check the electrical installation.
- Cause** The pump is blocked by impurities.
- Remedy**
1. Clean the pump.
  2. Clean or replace the strainer in the inlet pipe.
- Cause** The motor is defective.
- Remedy** Replace the pump.

**8.2 The pump stops unexpectedly during operation and starts again after a while**

The thermal switch in the motor has tripped due to overheating and runs intermittent operation. The thermal switch will cut in automatically when the motor has cooled sufficiently. If the problem persists, check the possible causes:

- Cause** The impeller is stuck.
- Remedy** Clean the pump.
- Cause** The motor is defective.
- Remedy** Replace the pump.
- Cause** The ambient temperature is too high.
- Remedy** Make sure the ambient temperature is below the maximum ambient temperature stated on the nameplate.

**8.3 The pump runs, but does not deliver the expected amount of water**

- Cause** The outlet pipe is blocked.
- In this case, the pump typically delivers a reduced quantity of water at a high pressure.
- Remedy** Clean the pipe or open the isolating valves, if any.
- Cause** The pump is not filled with water.
- Remedy** Prime the pump.
- Cause** The inlet pipe is blocked by impurities.
- Remedy** Clean the inlet pipe. Clean or replace the strainer in the inlet pipe.
- Cause** The pump is blocked by impurities.
- Remedy** Clean the pump. Clean or replace the strainer in the inlet pipe.

- Cause** The suction lift is too high.
- Remedy** Change the position of the pump. The suction lift must not exceed 8 m.
- Cause** The inlet pipe is too long.
- Remedy** Change the position of the pump.
- Cause** The diameter of the inlet pipe is too small.
- Remedy** Replace the inlet pipe.
- Cause** The inlet pipe is not immersed deeply enough.
- Remedy** Make sure that the inlet pipe is immersed sufficiently.
- Cause** The inlet pipe is leaking.
- Remedy** Repair or replace the pipe.

**8.4 Fault finding boosters with a pressure manager****8.4.1 Operating panel for pressure manager PM 1**

Fig. Operating panel on pressure manager PM 1

Pos.	Symbol	Description
1	Power on	The green indicator light is permanently on when the power is on.
2	Pump on	The green indicator light is permanently on when the pump is running.
3	Alarm	The red indicator light is permanently on or flashes when the pump has stopped due to an operating fault.
4	Reset	The reset button is used for the following: <ul style="list-style-type: none"> <li>• resetting fault indications</li> <li>• enabling and disabling the anti-cycling function.</li> </ul>

For indicator light check, all indicator lights illuminate when the power is switched on.

**8.4.2 The "Alarm" indicator light flashes once at a regular interval**

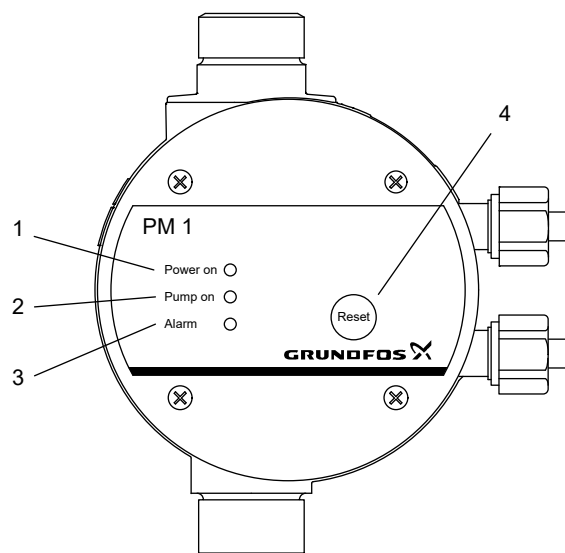
For systems without a pressure tank.

The anti-cycling function has stopped the pump because the pump starts and stops too frequently.

**Cause** A tap has not been entirely closed after use.

**Remedy** Make sure all taps are closed.

**Cause** There is a minor leakage in the system.

**Remedy** Make sure there are no leakages in the system.

#### 8.4.3 The "Alarm" indicator light is permanently on

**Cause** **Dry running. The pump needs water.**

The pump has stopped due to the dry-running function.

**Remedy** Make sure that the water supply is sufficient.

**Cause** **The power supply to the pump is disconnected.**

**Remedy** Check the plug and cable connections, and make sure that the built-in circuit breaker of the pump is switched off.

**Cause** **The motor protection of the pump has tripped due to overload.**

**Remedy** Make sure the motor or pump is not blocked.

**Cause** **The pressure manager is defective.**

**Remedy** Repair or replace the pressure manager. Find more information in the service instructions at <https://product-selection.grundfos.com>.

#### 8.4.4 The "Power on" indicator light is off even though the power supply has been switched on

**Cause** **The fuses in the electrical installation have blown.**

**Remedy** Replace the fuses. If the new fuses also blow, check the electrical installation for malfunctions.

**Cause** **The earth-leakage circuit breaker or the voltage-operated circuit breaker has tripped.**

**Remedy** Cut in the circuit breaker.

**Cause** **The pressure manager is defective.**

**Remedy** Repair or replace the pressure manager. Find more information in the service instructions at <https://product-selection.grundfos.com>.

#### 8.4.5 The "Pump on" indicator light is on, but the pump does not start

**Cause** **The power supply to the pump is disconnected.**

**Remedy** Check the plug and cable connections, and make sure that the built-in circuit breaker of the pump is switched off.

**Cause** **The motor protection of the pump has tripped due to overload.**

**Remedy** Make sure the motor or pump is not blocked.

**Cause** **The pump is defective.**

**Remedy** Repair or replace the pump.

**Cause** **The pressure manager is defective.**

**Remedy** Repair or replace the pressure manager. Find more information in the service instructions at <https://product-selection.grundfos.com>

#### 8.4.6 The pump does not start when water is consumed

The "Pump on" indicator light is off.

**Cause** **There is too big a difference in height between the pressure manager and the tapping point.**

**Remedy** Adjust the installation, or increase the start pressure.

**Cause** **The pressure manager is defective.**

**Remedy** Repair or replace the pressure manager. Find more information in the service instructions at <https://product-selection.grundfos.com>.

#### 8.4.7 The pump does not stop

**Cause** **The pump cannot deliver the necessary outlet pressure.**

**Remedy** Replace the pump.

**Cause** **The start pressure is set too high.**

**Remedy**

- PM 1: The start pressure is factory set. Make sure that your product is dimensioned correctly.
- PM 2, PM TWIN: Decrease the start pressure.

**Cause** **The non-return valve is stuck in open position.**

**Remedy** Clean or replace the non-return valve.

**Cause** **The pressure manager is defective.**

**Remedy** Repair or replace the pressure manager. Find more information in the service instructions at <https://product-selection.grundfos.com>.

### 8.5 Fault finding boosters with a pressure tank

#### 8.5.1 The booster starts and stops too frequently

**Cause** **Incorrect precharge pressure.**

**Remedy** Adjust the diaphragm tank pressure.

**Cause** **Leakage in pipes.**

**Remedy** Check and repair the pipes.

**Cause** **The diaphragm is broken. Water escapes if the air valve is pushed down.**

**Remedy** Replace the pressure tank.

## 9. Technical data

### 9.1 Operating conditions

System pressure	Max. 6 bar / 0.60 MPa
Suction lift	Max. 8 m, including inlet-pipe pressure loss at a liquid temperature of 20 °C
Liquid temperature	Max. 40 °C (S1) / 60 °C (S3*)
Ambient temperature	Max. 40 °C (S1) / 55 °C (S3*)
Relative humidity	Max. 98 %
Enclosure class	IP44
Insulation class	F
Supply voltage	1 x 220-240 V, 50/60 Hz 1 x 115 V, 60 Hz
Start/stop frequency	Max. 20 per hour
Sound pressure level	Max. sound pressure level of the pump: JP 3-42: 68 [dB(A)] JP 4-47: 70 [dB(A)] JP 4-54: 74 [dB(A)] JP 5-48: 81 [dB(A)]

### 9.2 Head and flow rate

Max. head	JP 3-42: 42 m
	JP 4-47: 47 m
	JP 4-54: 54 m
	JP 5-48: 48 m
Max. flow rate	JP 3-42: 3 m <sup>3</sup> /h
	JP 4-47: 4 m <sup>3</sup> /h
	JP 4-54: 4 m <sup>3</sup> /h
	JP 5-48: 5 m <sup>3</sup> /h

### 9.3 Inlet pressure

Max. inlet pressure	JP 3-42: 1.5 bar / 0.15 MPa
	JP 4-47: 1.0 bar / 0.10 MPa
	JP 4-54: 0.5 bar / 0.05 MPa
	JP 5-48: 1.0 bar / 0.10 MPa

### 9.4 Miscellaneous data

Cut-in pressure	Preset cut-in pressure (start pressure):
	JP PM: 1.5 bar
	JP PT-V: 2.2 bar
	JP PT-H: 2.2 bar
Min./max. storage temperature	-20/+70 °C

## 10. Disposing of the product

This product or parts of it must be disposed of in an environmentally sound way.

1. Use the public or private waste collection service.
2. If this is not possible, contact the nearest Grundfos company or service workshop.
3. Dispose of the waste battery through the national collective schemes. If in doubt, contact your local Grundfos company.



The crossed-out wheellie bin symbol on a product means that it must be disposed of separately from household waste. When a product marked with this symbol reaches its end of life, take it to a collection point designated by the local waste disposal authorities. The separate collection and recycling of such products will help protect the environment and human health.

See also end-of-life information at [www.grundfos.com/product-recycling](http://www.grundfos.com/product-recycling).

Превод на оригиналната английска версия

**Съдържание**

<b>1. Обща информация</b>	<b>18</b>
1.1 Целева група	18
1.2 Предупредителни текстове за опасност	18
1.3 Бележки	18
<b>2. Получаване на продукта</b>	<b>18</b>
2.1 Оглед на продукта	18
2.2 Съдържание на доставяния комплект, JP	19
2.3 Съдържание на доставяния комплект, JP Booster	19
<b>3. Инсталиране на продукта</b>	<b>19</b>
3.1 Местоположение	19
3.2 Механичен монтаж	19
3.3 Електрическо свързване	22
<b>4. Първоначално стартиране на продукта</b>	<b>24</b>
4.1 Напълване на продукта	24
4.2 Стартиране на продукта	24
<b>5. Представяне на продукта</b>	<b>25</b>
5.1 Обзор на продукта, JP	25
5.2 Обзор на продукта, JP Booster	26
5.3 Употреба по предназначение	26
5.4 Работни течности	26
5.5 Идентификация	26
<b>6. Обслужване</b>	<b>27</b>
6.1 Поддръжка	27
6.2 Поддръжка на разширителния съд	27
6.3 Сервизни комплекти	27
<b>7. Извеждане на продукта от експлоатация</b>	<b>27</b>
7.1 Източване на JP и JP PT-V	28
7.2 Източване на JP PT-N	28
7.3 Съхранение на продукта	28
7.4 Защита от замръзване	28
<b>8. Откриване на неизправности в продукта</b>	<b>28</b>
8.1 Помпата не се стартира	29
8.2 Помпата неочаквано спира по време на работа и малко след това се стартира отново	29
8.3 Помпата работи, но не подава очакваното количество вода	29
8.4 Откриване на неизправности в бустери с диспечер на налягането	29
8.5 Откриване на неизправности в бустери с разширителен съд	30
<b>9. Технически данни</b>	<b>31</b>
9.1 Работни условия	31
9.2 Напор и дебит	31
9.3 Входно налягане	31
9.4 Допълнителни данни	31
<b>10. Бракуване на продукта</b>	<b>31</b>

**1. Обща информация**

Този уред може да се използва от деца на 8 и повече години и лица с физически, сетивни или умствени увреждания или липса на опит и познания, ако са под надзор или им е проведено обучение относно безопасното използване на продукта и ако разбират свързаните с него опасности.

Не се допуска деца да си играят с уреда. Почистването и поддръжката на продукта от потребителя не трябва да се извършва от деца без надзор.



Прочетете настоящия документ, преди да инсталирате продукта. Монтажът и експлоатацията трябва да отговарят на местната нормативна уредба и утвърдените правила за добра практика.

**1.1 Целева група**

Настоящите инструкции за монтаж и експлоатация са предназначени за професионални, както и за непрофесионални потребители.

**1.2 Предупредителни текстове за опасност**

В инструкциите за монтаж и експлоатация, инструкциите за безопасност и сервизните инструкции на Grundfos може да се появяват символите и предупредителните текстове за опасност по-долу.

**ОПАСНОСТ**

Обозначава опасна ситуация, която ще доведе до смърт или тежки наранявания, ако не бъде избегната.

**ПРЕДУПРЕЖДЕНИЕ**

Обозначава опасна ситуация, която може да доведе до смърт или тежки наранявания, ако не бъде избегната.

**ВНИМАНИЕ**

Обозначава опасна ситуация, която може да доведе до леки или средни наранявания, ако не бъде избегната.

Предупредителните текстове за опасност са структурирани по следния начин:

**СИГНАЛИЗИРАЩА ДУМА****Описание на опасността**

Последствия от пренебрегването на предупреждението

- Действия за избягване на опасността.

**1.3 Бележки**

В инструкциите за монтаж и експлоатация, инструкциите за безопасност и сервизните инструкции на Grundfos може да се появяват символите и бележките по-долу.



Съблюдавайте тези инструкции при работа с взривобезопасни продукти.



Син или сив кръг с бял графичен символ обозначава, че трябва да се предприеме действие.



Червен или сив кръг с диагонална лента, обикновено с черен графичен символ, обозначава, че определено действие трябва да не се предприема или да бъде преустановено.



Неспазването на тези инструкции може да доведе до неизправност или повреда на оборудването.



Съвети и препоръки, които улесняват работата.

**2. Получаване на продукта****2.1 Оглед на продукта**

При получаването на продукта направете следното:

1. Проверете дали продуктът е точно този, който е поръчан. Ако продуктът не е поръчаният, свържете се с доставчика.
2. Уверете се, че захранващото напрежение и честота съответстват на стойностите, описани на табелката с данни.

### Свързана информация

#### 5.5.1 Пример за табелка с данни на JP и JP Booster

### 2.2 Съдържание на доставяния комплект, JP

Кашонът съдържа следните артикули:

- 1 помпа Grundfos JP
- 1 комплект дръжка за повдигане
- 1 кратко ръководство
- 1 книжка с инструкции за безопасност.

### 2.3 Съдържание на доставяния комплект, JP Booster

Кашонът съдържа следните артикули:

- 1 Grundfos JP Booster
- 1 кратко ръководство
- 1 книжка с инструкции за безопасност.

## 3. Инсталиране на продукта

### 3.1 Местоположение

Продуктът може да се монтира и в помещение, и на открито. Използвайте подходящ навес, за да защитите продукта от пряка слънчева светлина, дъжд или сняг.

Моля, съблюдавайте следното:

- Монтирайте продукта на проветриво място, за да се осигури охлаждане за компонентите му.
- Инсталирайте продукта така, че да може лесно да извършват огледи, поддръжка и обслужване.
- Препоръчваме ви да разположите продукта възможно най-близо до течността за изпомпване.
- Препоръчваме ви да монтирате продукта близо до канал или отточен съд, свързан към канал, за да се отвежда евентуалната кондензация от студените повърхности.

### Свързана информация

#### 3.1.2 Околна температура по време на работа

#### 3.1.1 Инсталиране на продукта в околна среда със замръзване

Защитете продукта срещу замръзване, ако той трябва да се монтира на открито, където е възможно да има замръзване.

#### 3.1.2 Околна температура по време на работа

Околната температура не трябва да надвишава 55°C.

#### Околна температура

До 40°C	Помпата може да работи непрекъснато.
от 40 до 55°C	Защитата срещу прегряване осигурява работа на помпата с прекъсвания, когато температурата на въздуха е твърде висока, за да се охлажда ефективно двигателят. Пример за цикъл с прекъсвания: помпата работи 20 минути и спира за 40 минути, преди отново да се стартира. Вижте таблицата по-долу.

#### Работа с прекъсване (режим S3)

40-55°C	50 Hz	60 Hz
JP 3-42	ВКЛЮЧЕНА: 20 мин ИЗКЛЮЧЕНА: 40 мин	ВКЛЮЧЕНА: 20 мин ИЗКЛЮЧЕНА: 40 мин
JP 4-47	ВКЛЮЧЕНА: 15 мин ИЗКЛЮЧЕНА: 45 мин	ВКЛЮЧЕНА: 10 мин ИЗКЛЮЧЕНА: 50 мин
JP 4-54	ВКЛЮЧЕНА: 20 мин ИЗКЛЮЧЕНА: 40 мин	ВКЛЮЧЕНА: 20 мин ИЗКЛЮЧЕНА: 40 мин
JP 5-48	ВКЛЮЧЕНА: 20 мин ИЗКЛЮЧЕНА: 40 мин	ВКЛЮЧЕНА: 30 мин ИЗКЛЮЧЕНА: 30 мин

### Свързана информация

#### 3.1 Местоположение

#### 3.1.3 Минимално пространство

Осигурете достатъчно пространство за обслужване и поддръжка, както и за охлаждане на двигателя.

- Препоръчваме отстояние по 0,5 m от трите страни на продукта.
- Двигателят се охлажда от вентилатор, затова не закривайте капака на вентилатора.
- Ако монтирате продукта с едната страна до стена, осигурете видимост за табелката с данни.

### 3.2 Механичен монтаж

#### ПРЕДУПРЕЖДЕНИЕ

#### Електрически удар

Смърт или тежки наранявания



- Преди започване на работа по продукта изключете ел. захранването. Трябва да е сигурно, че захранването не може да бъде включено случайно.

#### ВНИМАНИЕ

#### Премазване на краката

Леки или средни наранявания



- При пренасяне на продукта носете предпазни обувки.

#### ВНИМАНИЕ

#### Замърсявания във водата

Леки или средни наранявания



- Преди да се използва помпата за водоснабдяване с питейна вода, промийте я щателно с чиста вода.

### 3.2.1 Монтаж на продукта

- Разположете продукта в хоризонтално положение с максимален ъгъл на наклон от  $\pm 5^\circ$ . Опорната плоча трябва да е насочена надолу.
- Закрепете продукта към здрав хоризонтален фундамент посредством винтове през отворите на опорната плоча.

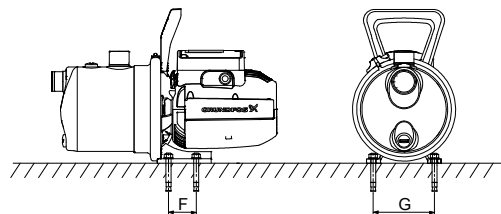

Фиг. Фундамент за помпа JP



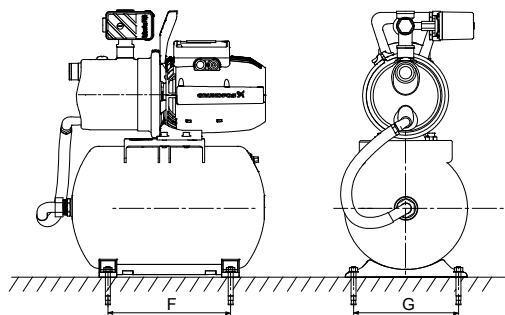

Фиг. Фундамент за бустер JP PT-H

	Помпа JP [mm]	Бустер JP PT-H [mm]
F	47	265
G	110	230

### 3.2.2 Прикрепване на дръжката за повдигане

Дръжката се доставя с помпата JP. Прикрепването на дръжката към помпата е по желание, например за помпи с постоянен монтаж.

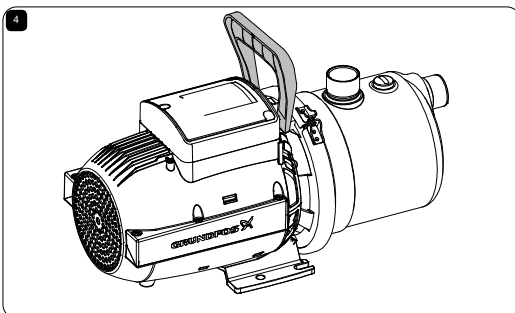
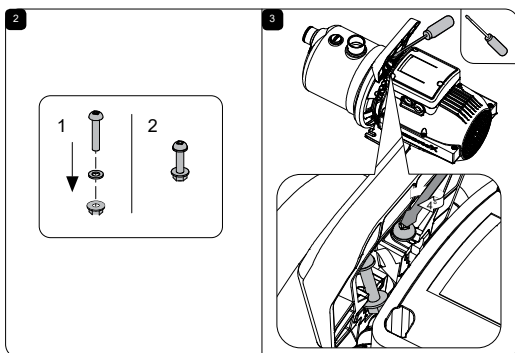
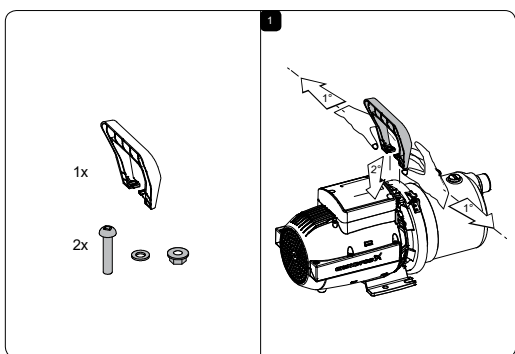

Фиг. Как се монтира дръжката за повдигане към помпата

### 3.2.3 Свързване на тръбната система

Монтирайте продукта така, че да не е под механично напрежение от тръбната система.

Размери на тръбите:

- Диаметърът на входната тръба трябва да е по-голям от 1", ако входната тръба е по-дълга от 10 m или смукателната височина надвишава 4 m.
- Ако за входна тръба се използва маркуч, той трябва да не може да се прегъва.



Препоръчваме ви да монтирате спирателни кранове от входната и изходната страна на помпата.

- Уплътнете фитингите на тръбите с уплътняваща лента за резби или подобно средство.
- Свържете тръбите към входния и изходния отвор на помпата. Не допускайте тежестта на тръбите да се носи от помпата. Използвайте тръбен ключ или подобен инструмент.
- Монтирайте подаващ вентил на входната тръба, ако помпата е монтирана над нивото на течността, например ако изпомпвате от кладенец, резервоар или басейн. Препоръчваме подаващ вентил с филтърна решетка.
- Препоръчваме да монтирате филтър от входната страна, за да предпазите помпата от пясък, чакъл и други частици, ако тя ще се използва за дъждовна вода или за кладенец.
- Осигурете входната тръба да има постоянен възходящ наклон от 5° към помпата, за да избегнете въздушни възглавници, особено при наличие на смукателна височина.

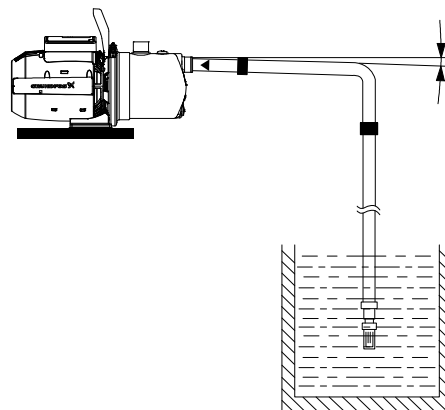

Фиг. Входна тръба с постоянен възходящ наклон към помпата

### 3.2.3.1 Максимално системно налягане

Уверете се, че системата, в която се инсталира помпата, е проектирана за максималното налягане на помпата.

Максималното входно налягане зависи от напора в действителната работна точка. Сумата от входното налягане и напора не трябва да надвишава максималното системно налягане.

Препоръчваме ви за защита на помпата да инсталирате контролен вентил за налягане, така че налягането на изхода да не надвиши максималното системно налягане.

### 3.2.3.2 Входни и изходни тръби

Моля, следвайте тези общи предпазни мерки, когато свързвате входната и изходната тръба.

Не допускайте тежестта на тръбите да се носи от помпата. Използвайте носачи или други опори за тръбите през равни интервали, за да осигурите опора за тежестта на тръбите близо до помпата.

Вътрешният диаметър на тръбите в никакъв случай не трябва да е по-малък от диаметъра на отворите на помпата.



<b>99520338</b> 122018
ECM: 1244124

Trademarks displayed in this material, including but not limited to Grundfos, the Grundfos logo and "be think innovate" are registered trademarks owned by The Grundfos Group. All rights reserved. © 2018 Grundfos Holding A/S, all rights reserved.

