



PERFORMANCE RANGE

- Flow rate up to **50 l/min** (3.0 m³/h)
- Head up to **75 m**

INSTALLATION AND USE

Ready-to-install cost-effective submersible pump, equipped with an integrated capacitor and thermal over-load protector.

Designed to transfer clean water free from abrasive particles and liquids that will not damage the pump's components.

Compact and cost-effective, it is suitable for domestic applications. It works seamlessly with small-sized pressure tanks, offering an ideal setup for all irrigation requirements.

APPLICATION LIMITS

- Liquid temperature up to **+40 °C**
- Depth of use up to **40 m** below water level (with an appropriately sized power cable)
- Vertical and horizontal operation

AVAILABLE UPON REQUEST

- ✘ **30 metres** long power cable
- ✘ Different voltage requirements 60 Hz frequency

CURVES AND PERFORMANCE DATA – HS=0 m

50 Hz

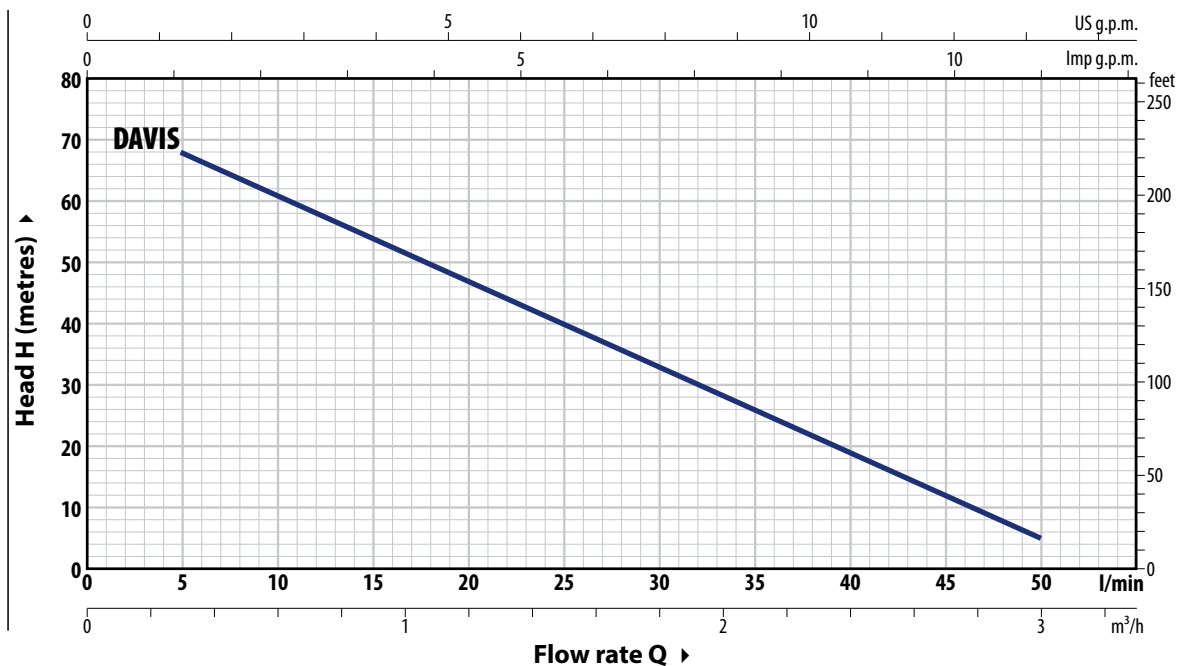

TYPE	POWER (P ₂)		Q	Flow rate												
	kW	HP		m ³ /h	0	0.3	0.6	0.9	1.2	1.5	1.8	2.1	2.4	2.7	3.0	
Single-phase			l/min	0	5	10	15	20	25	30	35	40	45	50		
DAVIS®	0.75	1	H metres	75	68	61	54	47	40	33	26	19	12	5		

Q = Flow rate H = Total manometric head

Performance curves comply with EN ISO 9906 Grade 3B tolerance limits.

MATERIALS AND COMPONENTS

1	Delivery port	Stainless steel AISI 304 complete with threaded delivery port in compliance with ISO 228/1	
2	Sealing cover	Brass	
3	Impeller	Brass, radial peripheral vane type	
4	Motor sleeve	Stainless steel AISI 304	
5	Motor shaft	Stainless steel AISI 431	
6	Two mechanical seals separated by an oil chamber	Type	Materials
		Shaft	
		Ø 14 mm	Ceramic / Graphite / NBR
		Ø 14 mm	Ceramic / Silicon carbide / NBR
7	Capacitor		
8	Electric motor	<ul style="list-style-type: none"> – Submersible PEDROLLO motor, suitable for continuous duty (with dry, rewindable stator). – Single-phase 220-230 V - 50 Hz – Built-in motor capacitor – Thermal motor protection incorporated in the winding – Continuous running duty S1 – Insulation: Class F – Protection rating: IP X8 	
9	✳ Power cord	<ul style="list-style-type: none"> ➡ DRINCABLE® HRC certified for use with drinking water meant for human consumption by the ACS according to XP P 41-250, approval no. 18 MAT NY 156 Standard length 20 metres 	

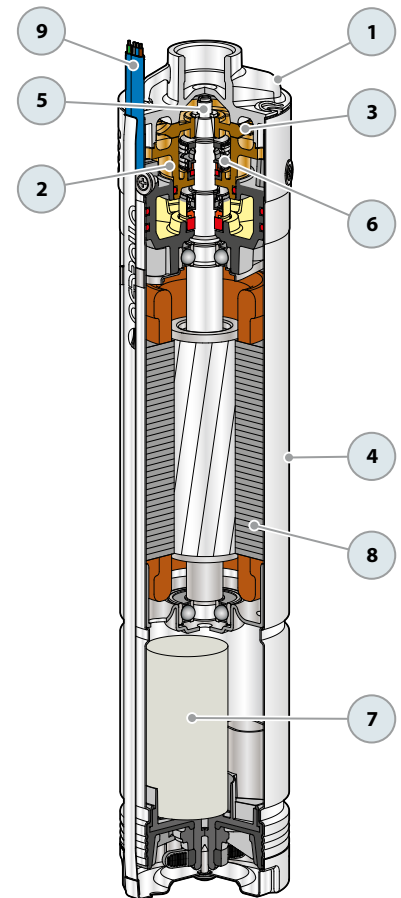

ABSORPTION

TYPE	VOLTAGE
Single-phase	230 V
DAVIS®	5.7 A

DIMENSIONS AND WEIGHT

TYPE	PORT	DIMENSIONS mm		kg
		DN	h	
Single-phase	DN	Ø	h	
DAVIS®	1"	101	470	12.6

PALLET CAPACITY

TYPE	NO. OF PUMPS
Single-phase	
DAVIS®	60

