



DC 80-102



DC 150



DC 80-102

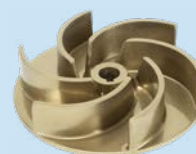

DC 150



Drainage pumps with set-back Vortex type impeller for pumping sewage waters and liquids with suspended solids; ideal for civil and household applications. The single-phase version includes a built-in capacitor, a thermal protector and it can be equipped with a float switch.

Construction features

Painting cataphoresis

Pump body cast iron

Shell, motor cover, base support stainless steel



Impeller Vortex stainless steel (80-102); brass (150)

Mechanical seal double seal with oil barrier: pump side with silicon carbide mechanical seal; motor side with sealing ring (80÷102) or ceramic-graphite mechanical seal (150)

Motor shaft stainless steel AISI 430

Free passage Ø max 35 mm (80-100)
Ø max 50 mm (82÷150)

Max submergence 5 m

Liquid temperature 0 - 40 °C

Cable H07 RN8F, 10 m

G float switch

Motor

3- 400V - 50Hz

2 Poles induction motor 1- 230V - 50Hz
(with thermal protection)

Insulation class F

Protection degree IPX8

TYPE	LOTS			
	TRUCK		CONTAINER	
	PALLET (cm)	N° pumps	PALLET (cm)	N° pumps
DC 80÷102	80×120×145	48	80×120×190	76
DC 150	80×120×160	51	80×120×160	51

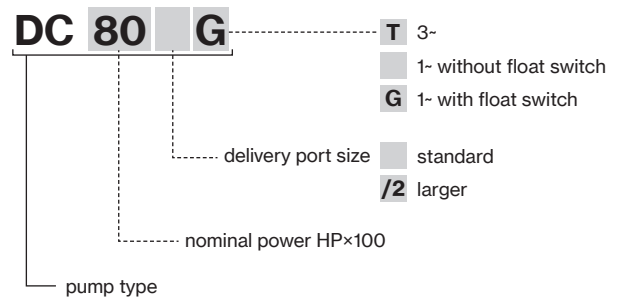

DC

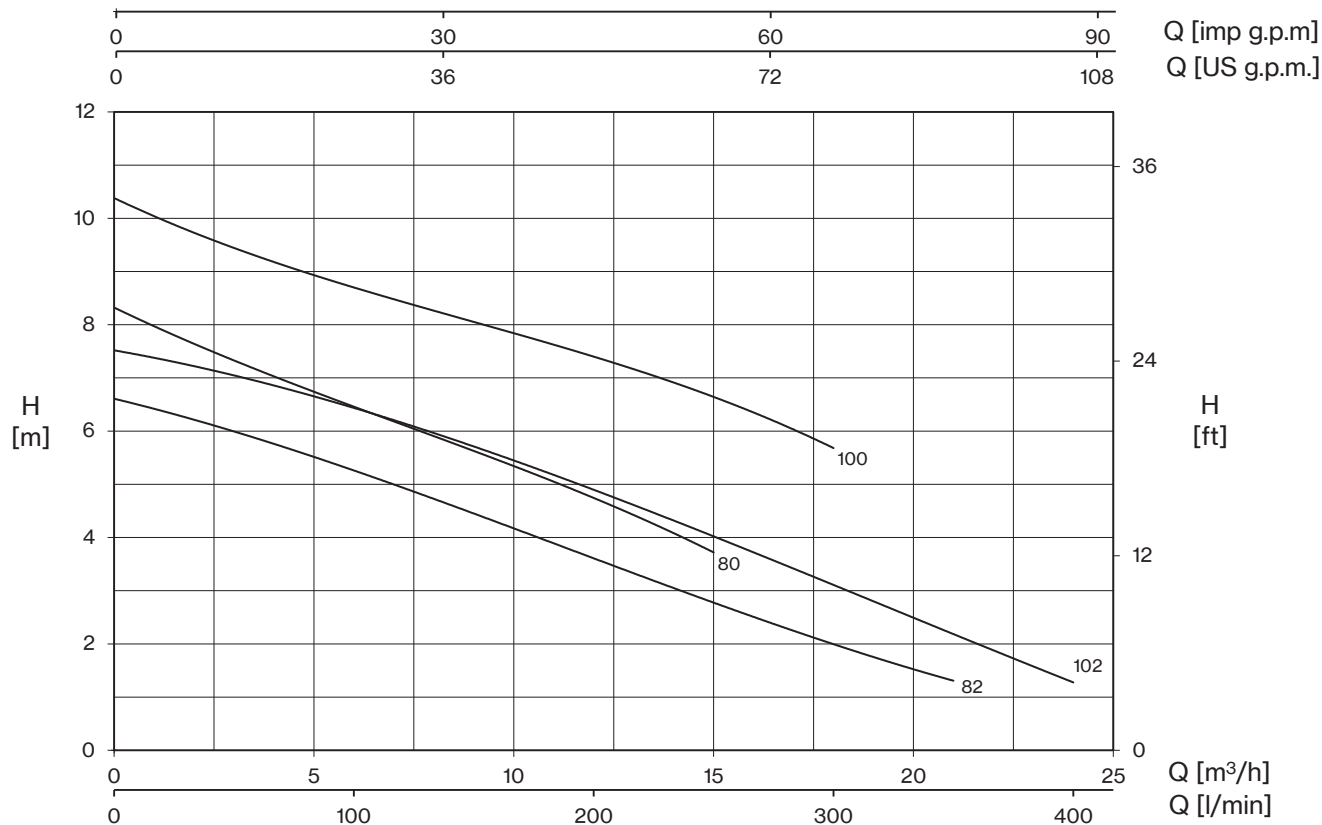

TYPE		W	AMPERE		Q (m³/h - l/min)										
1~	3~		1~	3~	0	3	6	9	12	15	18	21	24		
					0	50	100	150	200	250	300	350	400		
		1- 230V 50 Hz		3- 400V 50 Hz		H (m)									
DC 80 (G)	DC 80T	1050	4,7	2,2	8,3	7,4	6,4	5,6	4,8	3,7					
DC 80/2 (G)	DC 80/2T	1050	4,7	2,2	8,3	7,4	6,4	5,6	4,8	3,7					
DC 100 (G)	DC 100T	1350	6,2	2,8	10,4	9,4	8,7	8,1	7,4	6,6	5,7				
DC 100/2 (G)	DC 100/2T	1350	6,2	2,8	10,4	9,4	8,7	8,1	7,4	6,6	5,7				
DC 82 (G)	DC 82T	1000	4,5	2,1	6,6	6	5,3	4,4	3,6	2,8	2	1,3			
DC 102 (G)	DC 102T	1200	5,3	2,4	7,5	7,1	6,4	5,7	4,9	4	3,2	2,1	1,3		

E: maximum emptying level
Mt: minimum liquid level for continuous duty

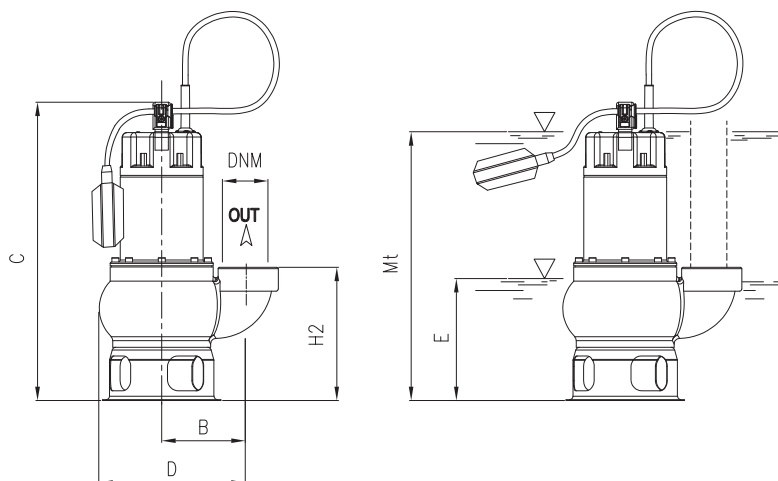

TYPE	DIMENSIONS (mm)										
	B	C	D	E	H2	Mt	DNM	I	L	M	
DC 80 (G)	110	410	230	140	174	290	1" 1/2 G	250	183	448	14
DC 80/2 (G)	110	410	230	140	174	290	2" G	250	183	448	14
DC 100 (G)	110	410	230	140	174	290	1" 1/2 G	250	183	448	15
DC 100/2 (G)	110	410	230	140	174	290	2" G	250	183	448	15,5
DC 82 (G)	120	426	250	150	190	300	2" G	265	205	500	15
DC 102 (G)	120	426	250	150	190	300	2" G	265	205	500	16

Q [imp g.p.m]
Q [US g.p.m.]

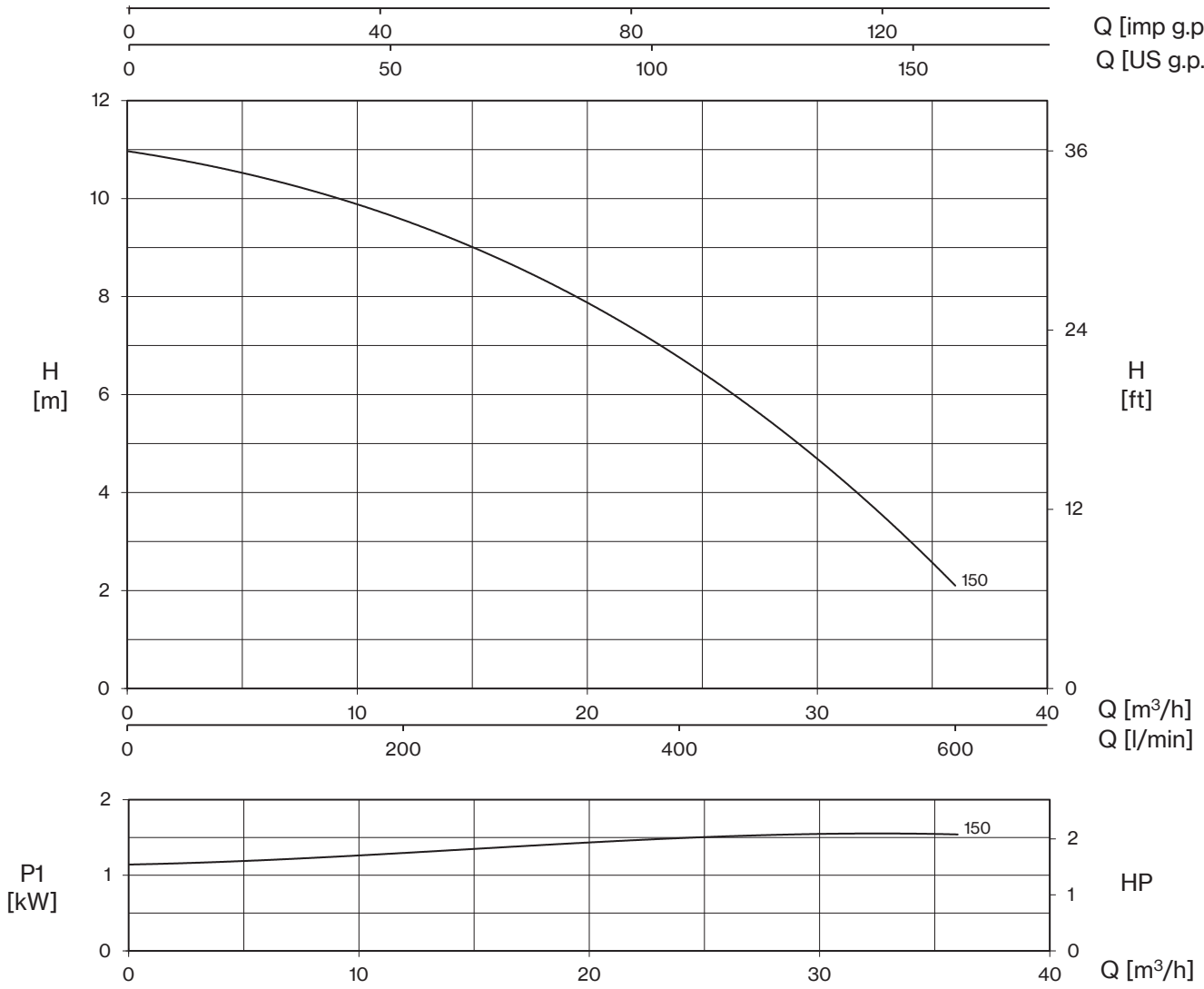

TYPE		W	AMPERE		Q (m³/h - l/min)							
1~	3~		1~	3~	0	6	12	18	24	30	36	
					0	100	200	300	400	500	600	
						H (m)						
DC 150 (G)	DC 150T	1550	1~ 230V 50 Hz	3~ 400V 50 Hz	11,0	10,4	9,6	8,3	6,8	4,6	2,1	

E: maximum emptying level
Mt: minimum liquid level for continuous duty

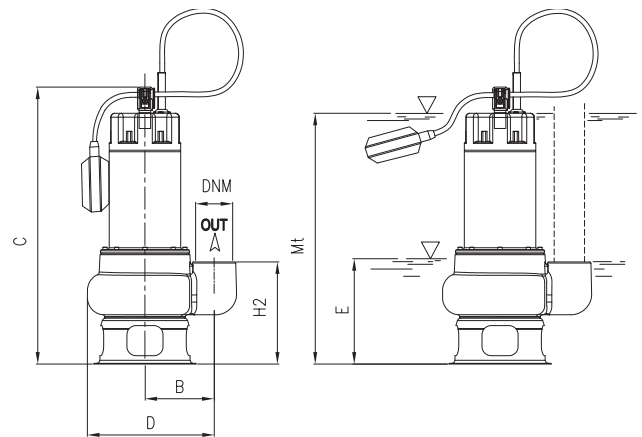

TYPE	DIMENSIONS (mm)											Kg
	B	C	D	E	H2	Mt	DNM	I	L	M		
DC 150 (G)	142,5	461	247,5	185	170	390	2" G	200	260	470	19	