



Dirty water



Domestic use

※ **FAMILY is an innovative and reliable stainless steel product**



PERFORMANCE RANGE

- Flow rate up to **250 l/min** (15 m³/h)
- Head up to **10 m**

INSTALLATION AND USE

The **FAMILY** pump is designed for **dirty water** and sewage drainage in **domestic settings**, capable of handling suspended solids up to **30 mm in diameter**. It's easy to operate and reliable in automated fixed installations.

INCLUDES

- ※ **5 m** power cable
- ※ Float switch
- ※ Rubber element holder

APPLICATION LIMITS

- Depth below water level up to **5 m** (with an appropriately sized power cable)
- Liquid temperature up to **+40 °C**
- Capable of processing suspended solids up to **Ø 30 mm**
- **Minimum immersion for continuous service: 160 mm**

AVAILABLE UPON REQUEST

- ※ Technopolymer impeller (economic)
- ※ Pumps with **10 m** power cable
- ※ Different voltage requirements 60 Hz frequency

PATENTS - TRADE MARKS - MODELS

- Patent No. IT0001428923

CURVES AND PERFORMANCE DATA

50 Hz

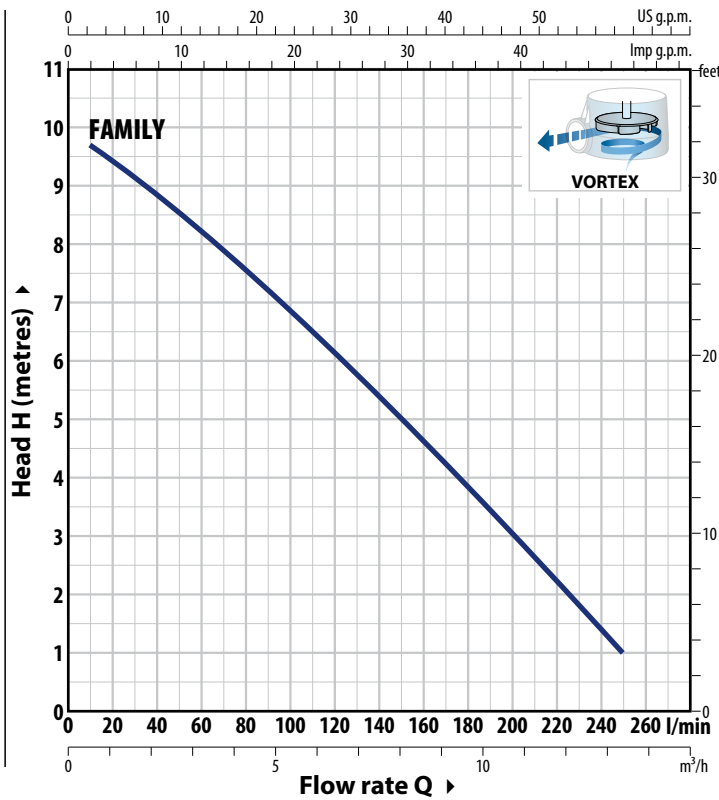

ABSORPTION

TYPE	VOLTAGE
Single-phase	230 V
FAMILY	3.0 A

TYPE	POWER (P ₂)		Q	Flow rate														
	kW	HP		m ³ /h	0	0.6	1.2	2.4	3.6	4.8	6	7.2	8.4	9.6	10.8	12	13.2	15
Single-phase			l/min	0	10	20	40	60	80	100	120	140	160	180	200	220	250	
FAMILY	0.50	0.70	H metres	10	9.7	9.4	9	8.2	7.6	7	6	5.4	4.6	3.7	3	2.2	1	

Q = Flow rate H = Total manometric head

Performance curves comply with EN ISO 9906 Grade 3B tolerance limits.

MATERIALS AND COMPONENTS

1 Pump body	AISI 304 stainless steel with ISO 228/1 threaded port		
2 Base	Stainless steel AISI 304		
3 Impeller	VORTEX type in AISI 304 stainless steel		
4 Motor sleeve	Stainless steel AISI 304		
5 Motor shaft	Stainless steel AISI 431		
6 Double shaft seal	Seal	Shaft	Materials
	STA-12R	Ø 12 mm	Ceramic / Graphite / NBR
	Shaft seal	Ø 12 x Ø 19 x H 5 mm	
7 Capacitor			
8 Electric motor	Single-phase 230 V - 50 Hz with winding integrated thermal motor protection - Insulation: class F - Protection rating: IP X8		
9 Power cord	Type 'H07 RN-F' with Schuko plug ※ Standard length 5 metres		
10 Float switch			
11 Tilting device for the float cable	Patent No. IT0001428923		
12 Hose holder (included in delivery)	Ø 50 mm		

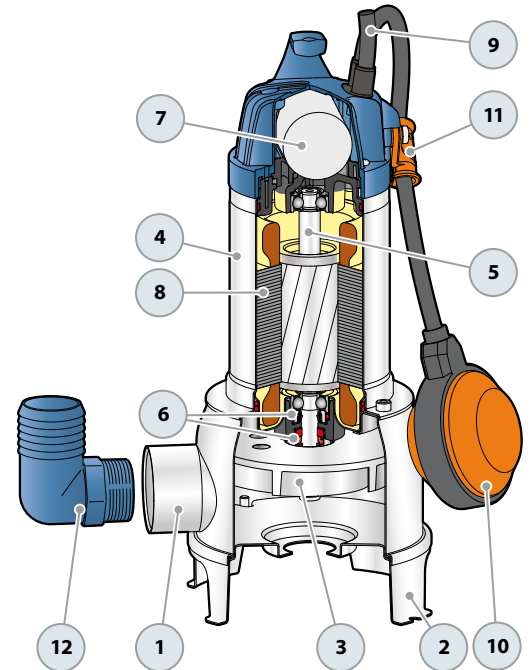

DIMENSIONS AND WEIGHT

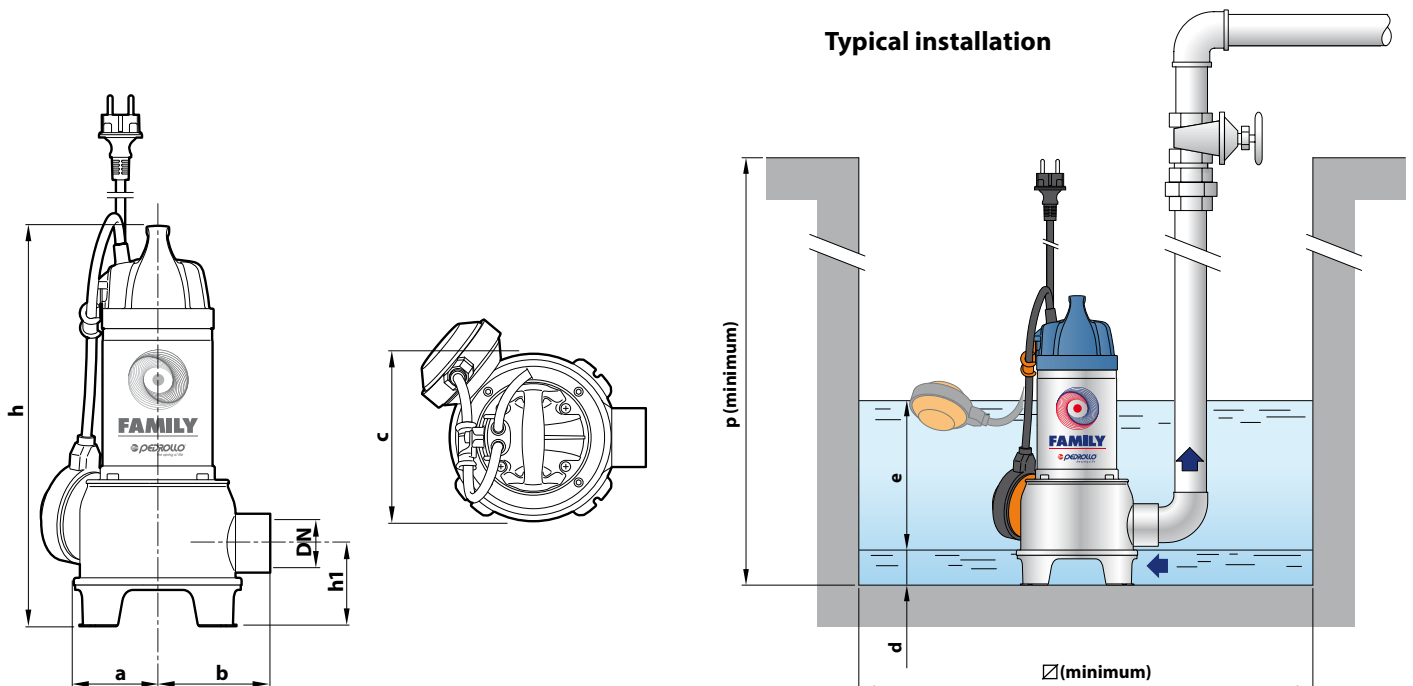

TYPE	PORT DN	Passage of solid bodies	DIMENSIONS mm									kg 1~	PALLET CAPACITY	
			a	b	c	h	h1	d	e	p	Ø			
Single-phase														
FAMILY	1½"	Ø 30 mm	70	93	140	333	68	40	adjustable	450	450	7.0	96	